

The 3600-PA Dual Action Tamp (DAT) Printer Applicator

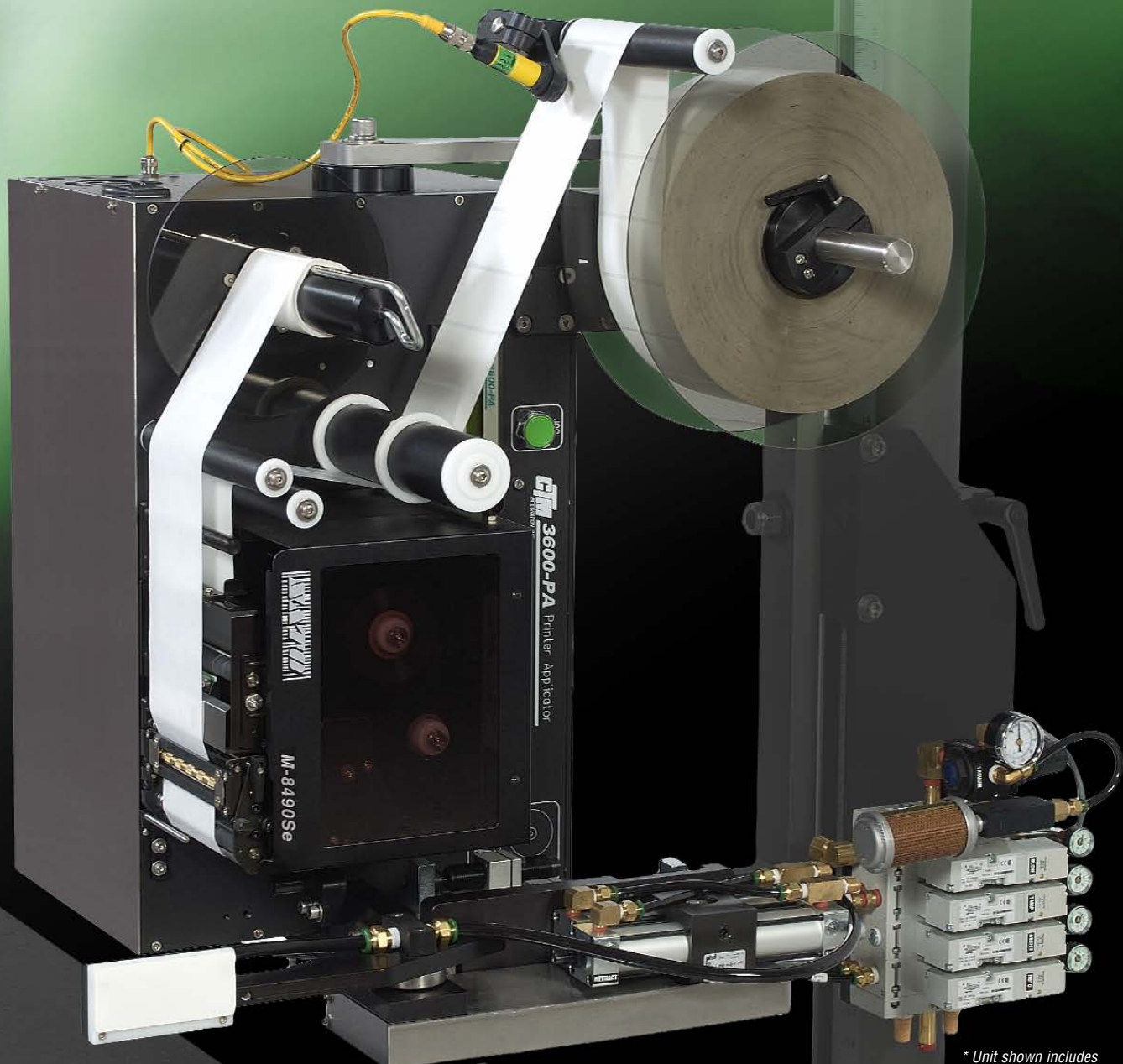

* Unit shown includes optional features

Innovations in Labeling

www.ctmint.com

3600-PA Dual Action Tamp (DAT) Printer Applicator

FEATURES

The 3600-PA Dual Action Tamp (DAT) Printer Applicator is a high speed, thermal transfer labeler used to print and apply pressure sensitive labels that can be programmed for single or two panel labeling applications applied to various cartons, cases or pallets. The single panel can be applied to either the front or the side.

Sato or Zebra print engine integrated into the applicator to print variable data.

Can be mounted in almost any position to apply labels to the leading, side or trailing panels of various products. Mounting can be oriented up or down depending upon label size and position on the product.

Short height actuator assembly allows the unit to reach over a conveyor to products which are not at the edge of the conveyor - 4" tall labels can be located 1/4" from the bottom of products.

Right hand or left hand version for either side of conveyor

Up to 7.1" wide labels, up to 6.6" print width

Built-in bar codes and alpha-numeric fonts

Proven tamp-blow application

PLC control

User-friendly operator interface with easy-to-read LCD display

Quick access to set-up parameters

Rugged and versatile for standard and custom applications

Equipped with multiple onboard I/O signals prewired to external connectors

DIMENSIONS

Dependent Upon Line Configuration

WEIGHT

Approx. 150 lbs.

ELECTRICAL

108-132 Volts AC, 5 Amps, 54/60 Hertz, Single Phase

PNEUMATIC

90 PSI., 3-5 CFM

COMMUNICATIONS

RS 232, Parallel - Others Available

ENVIRONMENTAL

Operating 41° F to 104° F (5° C to 40° C)

Storage -4° F to 104° F (-20° C to 40° C)

PRINTING METHOD

Thermal Transfer, Direct Thermal

PRINT RESOLUTION

203, 305 or 600 dpi, Dependent Upon Print Engine

PRODUCT SENSING

Photoelectric, PLC Input

APPLICATOR CONTROL

Micro PLC with Operator Key-Pad and 2-Line Display

**For Print Speed, Fonts, Bar Codes or Graphics,
See Programming Manual of Printer Manufacturer.**

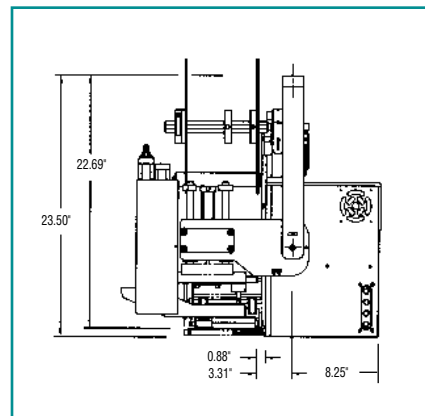
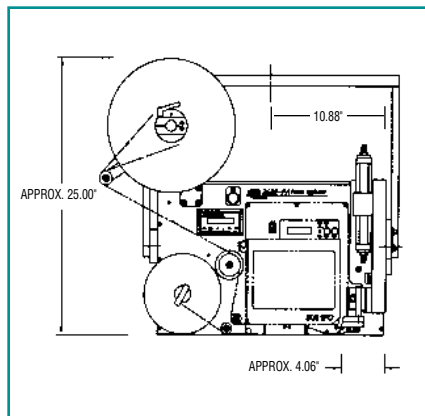
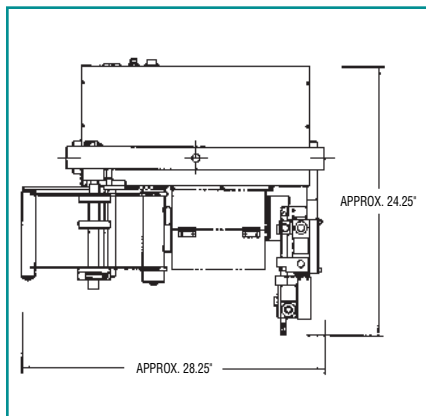

Distributed By:

CTM **INTEGRATION INC.**
Labeling Systems Built to Last

1318 Quaker Circle
P.O. Box 589
Salem, Ohio 44460

(330) 332-1800
www.ctmint.com